













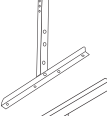
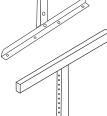

LIST OF PARTS

Part	Drawing	Description	Qty
P1		36x24 Table Top	1
P2		17x21 Partition	2
P3		10x29 Shelf	1
P4		17x36 Back Piece	1
P5		Upper Leg	2
P6		Leg Insert	2
P7		Stretcher Bar	1

HARDWARE LIST

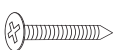
Part	Drawing	Description	Qty
A		Bolt	4
B		Nut	4
C		Washer	4
D		Wrench	1
E		Upper Leg Screws	8
F		Leg Insert Screws	6
G		Glide	4
H		2" Screws	13
I		2 1/2" Screws	8

TO ASSEMBLE:

We suggest that 2 people assemble this Carrel. The assembly for this carrel is quick and extremely easy, thanks to our dowel pin method.

1. Identify and separate all the parts and hardware.
2. Place the 36x24 table top [P1] upside down on a flat surface. Attach the [P5] upper legs with the [P7] stretcher bar. First line up the holes of the upper leg with the 2 holes in the stretcher bar's bracket, **as shown in Illustration #1**. Insert the [A] bolt from the outside of the leg and place the [C] washer and [B] nut inside, once the bolt is through the leg. Tighten the [B] nut. Repeat on the other side.
3. Properly align the upper leg bracket in the center of the table's width. There are locator marks for assembly ease. Use 4 [E] screws to attach each upper leg to the underside of the table top. **See Illustration #1**
4. Install the [P6] leg inserts into the [P5] upper legs, **as shown in Illustration #1**. The holes in the legs are 1" apart. Set at desired height and tighten using 3 [F] screws per leg. Screw the [G] glide on the bottom of the T-legs.

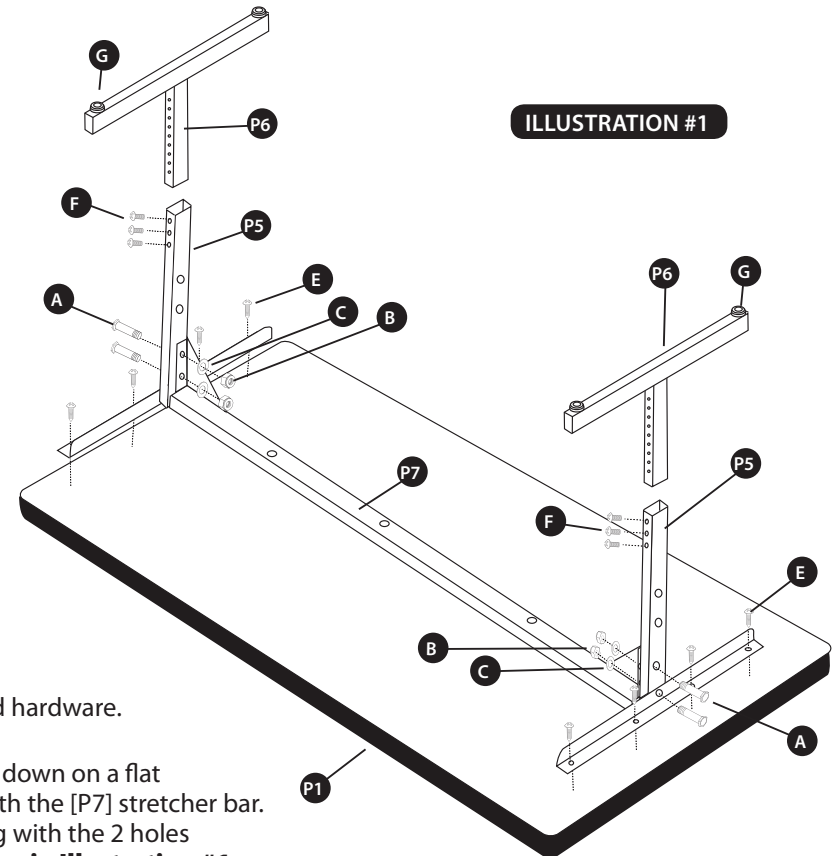

5. Place the [P2] partitions' dowel pins into the holes in the [P1] table top, **See Illustration #2.**

6. Carefully place the [P3] shelf in between the [P2] partitions, inserting the shelf's dowel pin edges into the partition holes. Finally, place the Carrel's [P4] back piece and lock into place. **See Illustration #2.**

7. Use 2½" screws [I] to attach the [P2] partitions to the [P1] table and the [P4] back piece to the [P1] table, **as shown in Illustration #2.** Use 3 screws per partition and 2 to attach the back piece to the table.

8. Use 2" screws [H] to attach [P4] back piece to [P2] partitions, [P4] back piece to [P3] shelf and [P2] partitions to [P3] shelf, **as shown in Illustration #2.**

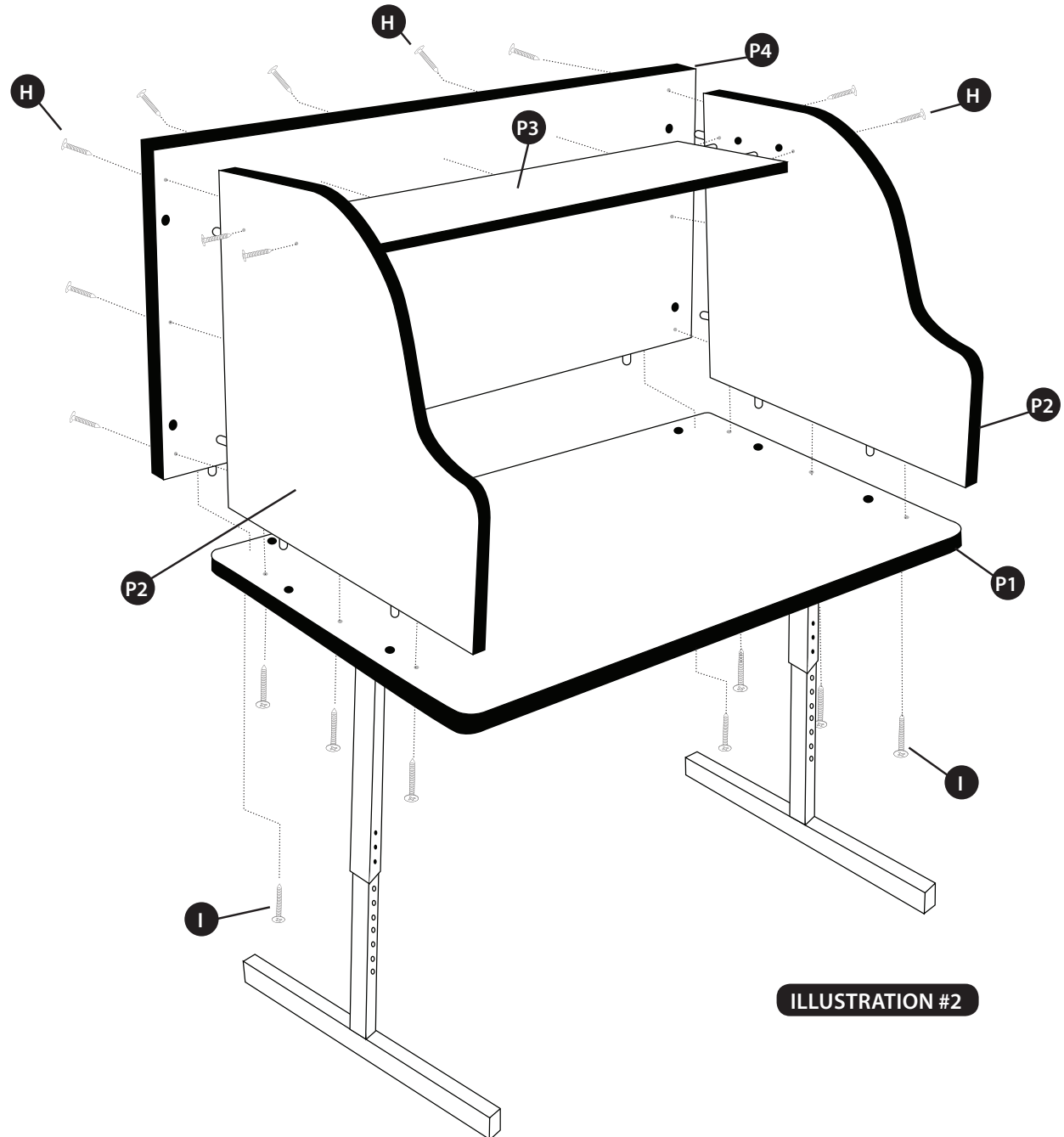

ILLUSTRATION #2